

Horizontal Flow Wrapping Machine

α wrapper X SERIES

Next generation horizontal flow wrapping machine is developed under the concept of
"A packaging machine that exceeds everyone needs".
We have achieved improved accuracy, enhanced safety, and improved operation performance.



Photo:FW3410/BαX



Photo:FW3400αX

Horizontal Flow Wrapping Machine



Features

- By increasing the maximum film outer diameter to 350mm, we have reduced the frequency of film change.
- Fixation of bagformer and overhead transfer brush is improved. It stabilizes packaging quality and improves repeatability.
- Implementing spline shaft on endseal vertical shaft, achieving stable operation under high pressure and high speed condition.
- Overhead transfer brush is lifted and fixed in upper position. Large working space allows quicker film passing operation and reduces cleaning time.
- High visible universal font is used for HMI and supporting 50 languages. Home screen can be customized to suit each customer and no hesitation for operation. Color at top of HMI changes according to machine status, allowing operators to check machine condition at a glance from a distance.
- Operator management can be controlled by RFID located underneath HMI.

Lift up type overhead transfer brush



Operator management by RFID



Standard Specifications

Machine Name		Horizontal Flow Wrapping Machine							
Machine Model		FW3400, FW3700		FW3400/B, FW3700/B		FW3410, FW3710		FW3410/B, FW3710/B	
Endseal Diameter		RD81	RD114	BD50	BD100	RD114	RD150	BD75	BD125
Speed (bags/min.)		10~300		10~250	10~150	10~300	10~150	10~150	10~120
Cut off length		60~250mm	80~350mm	80~170mm	100~340mm	100~350mm	120~450mm	90~250mm	130~430mm
		(Up to 3,999mm according to spec.)				(Up to 3,999mm according to spec.)			
Product Size	Height	Up to 30mm	Up to 60mm	Up to 30mm	Up to 80mm	Up to 60mm	Up to 100mm	Up to 60mm	Up to 100mm
	Width	Up to 140mm				Up to 200mm			
Film width		W: Up to 450mm Outer diameter: Up to 350mm				W: Up to 650mm Outer diameter: Up to 350mm			
Characteristic of packed product		Solid foods, pharmaceuticals, and industrial products, etc.				Solid foods, pharmaceuticals, and industrial products, etc.			
Characteristic of film material		Heatsealable film				Heatsealable film			
Motor capacity		2.5kW		2.7kW		2.5kW		2.7kW	
Heater capacity		1.42kW	1.82kW	1.82kW		2.32kW			
Electricity		3 phase AC200V 50/60Hz 30A				3 phase AC200V 50/60Hz 30A			
Power consumption (Maximum)		3.92kW(10kW)	4.32kW(10kW)	4.52kW(10kW)		4.82kW(10kW)		5.02kW(10kW)	
Machine weight		Approx.1,100kg		Approx.1,300kg		Approx.1,150kg		Approx.1,350kg	
Operating environment		Surrounding temp: 0~40°C, Humidity: 30~80% (No condensation)				Surrounding temp: 0~40°C, Humidity: 30~80% (No condensation)			

Note 1) Specifications of the machine may differ based on characteristics and size of product, as well as characteristics, thickness, and other conditions of film material.
 Note 2) Power consumption is a theoretical value. Actual consumption may differ depending on the machine specifications.

Dimension Drawing

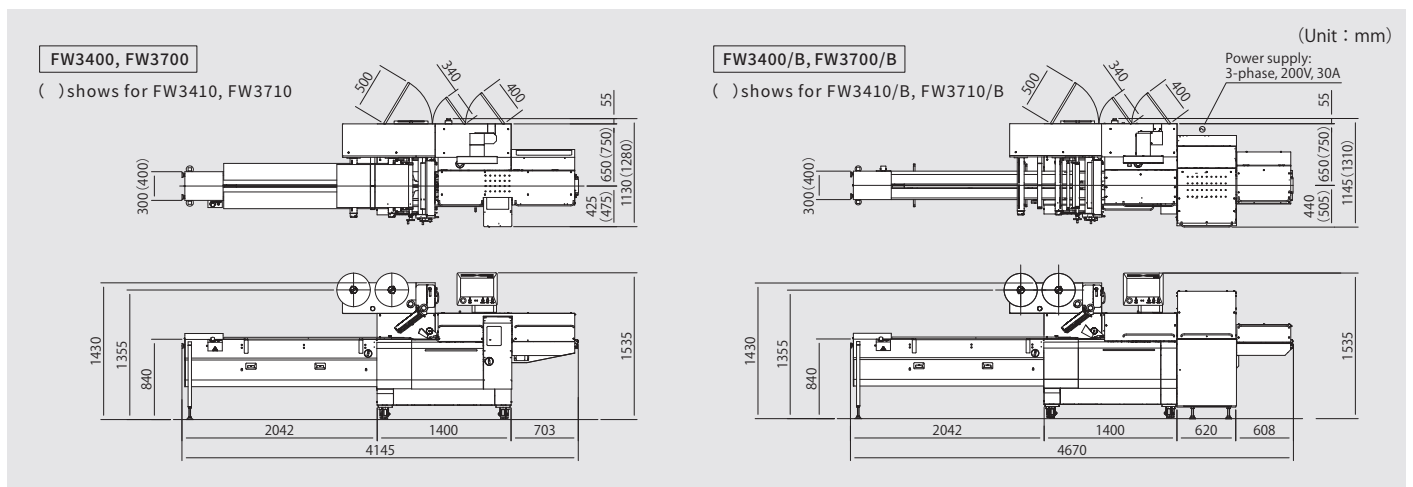

THE BASE NAGOYA

Nishinokawa 91, Okimura, Kitanagoya, Aichi, 481-0043, Japan

Phone 0568-20-9307 FAX 0568-20-9331

URL <https://www.fuji-machinery.com> E-mail : fuji@fuji-machinery.com

